

Physics 536 - Assignment #2 - Due January 30th Now with a new and improved question #3!

1. Consider the following circuit which consists of a voltage source, V , a current source, I , and three equal resistances, R :

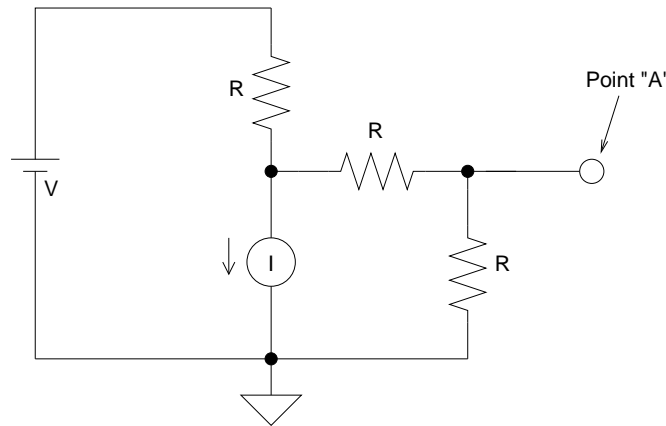

- (a) Draw Thevenin's equivalent circuit for the voltage source at point "A" and calculate V_{TH} and R_{TH} .
 (b) Draw Norton's equivalent circuit for the voltage source at point "A" and calculate I_N and R_N .

2. The following circuit consists of an arbitrary voltage source $v(t)$ in series with a resistance R_S and a load resistance R_L .

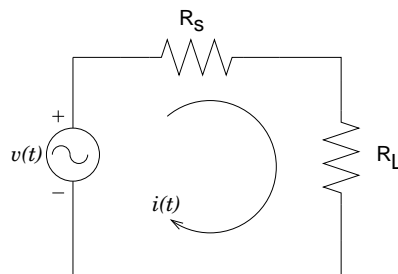

Calculate the value of R_L that maximizes the power dissipated by the load.

3. An oscilloscope probe that is used to observe a voltage source with an impedance of $Z = 50 \Omega$ can be modelled using the following equivalent circuit:

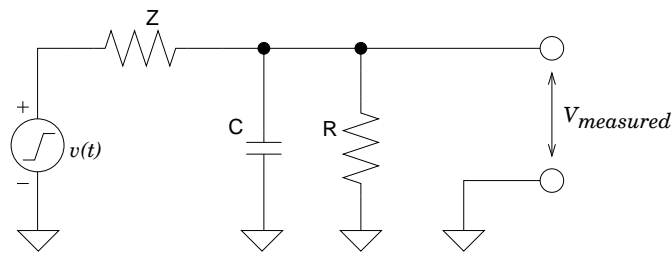

where typical values of the components are

$$R = 10 \text{ M}\Omega$$

$$C = 10 \text{ pF}$$

Calculate the time needed for the measured waveform to reach 90% of its maximum amplitude in response to a step pulse $v(t)$ with a very fast rise time (*ie.*, much shorter than ZC).

4. Consider the following circuit:

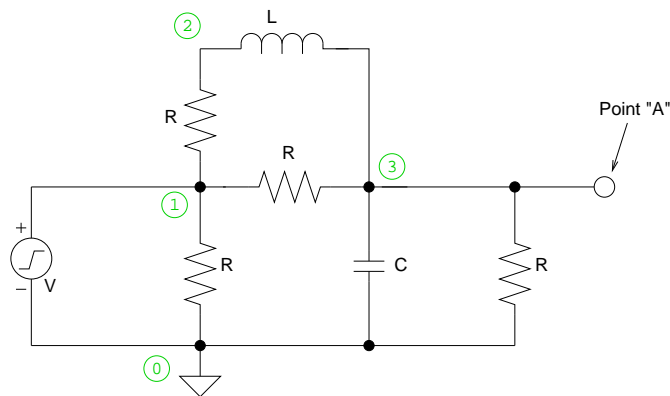

(a) If the voltage source makes a transition from 0 to V at $t = 0$, calculate the voltage at point "A" in the limit $t \rightarrow \infty$.

(b) Using the following component values:

$$\begin{aligned}C &= 5 \mu\text{F} \\L &= 5 \mu\text{H} \\R &= 1 \Omega \\V &= \begin{cases} 0 \text{ V} & \text{when } t < 0 \\ 5 \text{ V} & \text{when } t > 0 \end{cases}\end{aligned}$$

write the SPICE netlist for this circuit. The time-dependent voltage source can be described using

`Vxxxx N+ N- PULSE(V1 V2)`

where `V1` is the initial voltage for $t < 0$ and `V2` is the voltage for $t > 0$.

(c) Use SPICE to calculate the DC operating point of this circuit. In this case, the voltage source should be described using a constant 5 V DC voltage source. Compare the calculated voltage at point "A" with the value determined in part (a). Attach the SPICE simulation output to your assignment.

(d) Use SPICE to calculate the time-dependent voltage at point "A" by performing the numerical integration of the circuit with the *transient* analysis: Include the line

`.TRAN 0.1US 50US`

to simulate the circuit for times $0 < t < 50 \mu\text{s}$ in $0.1 \mu\text{s}$ time steps, and include the line

`.PRINT TRAN V(3)`

to print and graph the voltage at node 3 (*ie.* point "A") as a function of time. Check that the behavior of the circuit as $t \rightarrow \infty$ is as expected. Print out and hand in the resulting graph.