

$$\vec{F} = \frac{1}{4\pi\epsilon_0} \frac{q_1 q_2}{r^2} \hat{r} \quad \vec{E} = \frac{\vec{F}}{q_0} \quad dE = \frac{1}{4\pi\epsilon_0} \frac{dq}{r^2}$$

$$\Phi_E = \oint \vec{E} \cdot d\vec{A} \quad \epsilon_0 \Phi_E = q$$

$$\vec{E} = \frac{\lambda}{2\pi\epsilon_0 r} \hat{r} \quad V_b - V_a = -\int_a^b \vec{E} \cdot d\vec{l}$$

$$V = \frac{1}{4\pi\epsilon_0} \frac{q}{r} \quad U = qV \quad E = -\left(\frac{dV}{dl}\right)$$

$$q = CV \quad C = \epsilon_0 \frac{A}{d} \quad C = \kappa C_0$$

$$R = \rho \frac{L}{A} \quad V = iR \quad P = iV$$

$$U = \frac{1}{2} CV^2 = \frac{1}{2} \frac{q^2}{C} \quad V = \mathcal{E} (1 - e^{-t/RC})$$

$$\frac{1}{4\pi\epsilon_0} = 9 \times 10^9 \text{ Nm}^2 / \text{C}^2 \quad \epsilon_0 = 8.85 \times 10^{-12} \text{ F/m}$$

$$e = 1.609 \times 10^{-19} \text{ C}$$

$$E_z = \frac{qz}{4\pi\epsilon_0 (z^2 + R^2)^{3/2}}$$

$$E_z = \frac{\sigma}{2\epsilon_0} \left[1 - \frac{z}{\sqrt{z^2 + r^2}} \right]$$

$$E = \frac{\lambda}{2\pi\epsilon_0 r}$$

- 1) A point charge $q_0=1\mu\text{C}$ is placed at the position $x=5\text{m}$ on the x -axis. Three point charges $q_1=-10\text{nC}$, $q_2=8\text{nC}$, and $q_3=5\text{nC}$ are also placed separately on the x -axis at the three positions $x=1\text{m}$, $x=3\text{m}$, and $x=7\text{m}$ WITHOUT SPECIFYING WHICH POSITION WOULD CORRESPOND TO WHICH OF THE THREE CHARGES. Arrange the three charges to find the maximum force on the point charge, q_0 , to point in the NEGATIVE- x -direction. The resultant force is (\mathbf{i} denotes the unit vector in the positive x -direction): [10 points.]

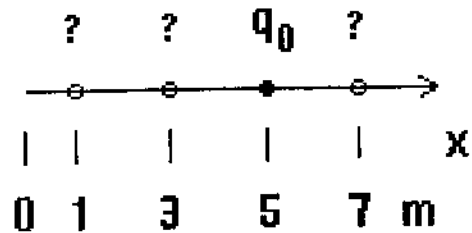

- (1) $-12.4 \mu\text{N } \mathbf{i}$
- (2) $+11.3 \mu\text{N } \mathbf{i}$
- (3) $-5.04 \text{ mN } \mathbf{k}$
- (4) $-37.7 \mu\text{N } \mathbf{i}$
- (5) $-38.5 \mu\text{N } \mathbf{j}$
- (6) $+4.35 \text{ mN } \mathbf{k}$
- (7) 0 N
- (8) $-36.5 \mu\text{N } \mathbf{i} + 11.3 \mu\text{N } \mathbf{k}$
- (9) $-67.5 \mu\text{N } \mathbf{i}$
- (10) $+433 \mu\text{N } \mathbf{i}$

- 2) Four charges: $q_1=1\text{mC}$, $q_2=-10\text{mC}$, $q_3=5\text{mC}$, and $q_4=-1\text{mC}$ sit on the four corners of a square of side 10cm in the x - y plane. Arrange the charges to yield the maximum (highest possible) total potential energy for the system. What is the resultant potential energy? (Note the energy is taken to be zero when two charges are infinitely separated and $?=2,3, \text{ or } 4$ and no charge occupies more than one corner.) [10 points.]

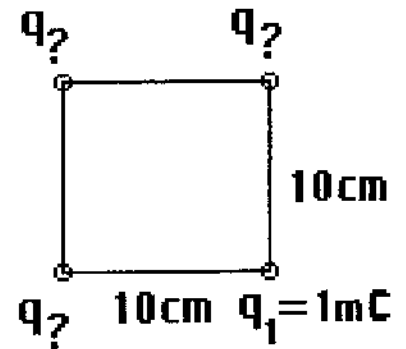

- (1) $-4.99\text{E}6 \text{ J}$
 (2) $-2.44\text{E}4 \text{ J}$
 (3) $-15.9 \mu\text{J}$
 (4) $-48.7 \mu\text{J}$
 (5) $-3.25\text{E}6 \text{ J}$
 (6) $-4.19\text{E}6 \text{ J}$
 (7) $+4.19\text{E}6 \text{ J}$
 (8) -3.5 mJ
 (9) -1.39 pJ
 (10) $+3.0\text{E}6 \text{ J}$

- 3) A closed, Gaussian surface consisting of the six surfaces of a rectangular box with one corner at the origin is drawn in the figure. The box has a square base of sides 1m in length and is 2m tall. Three point charges are placed at three distinct positions as follows: $q_1=5\text{nC}$ at (x,y,z) coordinates $(0.2\text{m},0.75\text{m},0.9\text{m})$, $q_2=14.6\text{nC}$ at $(1.35\text{m},0.2\text{m},1.4\text{m})$, and $q_3=24\text{nC}$ at $(0.5\text{m},0.5\text{m},4\text{m})$. Find the total electric flux through the Gaussian surface. [10 points.]

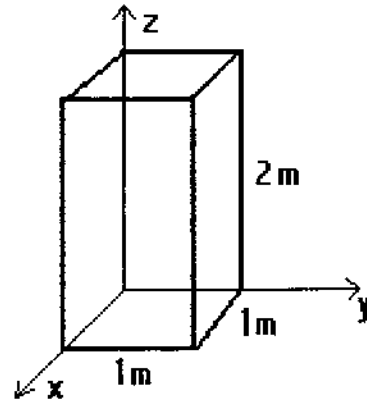

- (1) 2.22E3 Vm
- (2) 4.93E3 Vm
- (3) 3.28E3 Vm
- (4) 4.37E3 Vm
- (5) 3.73E2 Vm
- (6) 6.5E-8 Vm
- (7) 4.86E-7 Vm
- (8) 3.64E-7 Vm
- (9) 5.65E2 Vm**
- (10) 5.48E-7 Vm

- 4) A capacitor is made up of two very long, concentric cylindrical conductors. The inner conductor has a radius $a=1\text{mm}$, while the outer conductor has a radius of $b=2\text{mm}$. A dielectric material with dielectric constant $\kappa=10$ fills the volume between the shells. Part I—What is the capacitance for 1 meter of length? [5 points.]

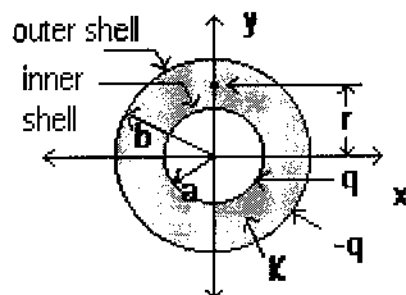

- | | |
|------|---------|
| (1) | 80.2 pF |
| (2) | 559 pF |
| (3) | 1.12 nF |
| (4) | 55.9 pF |
| (5) | 112 pF |
| (6) | 802 pF |
| (7) | 45 nF |
| (8) | 37.3 mF |
| (9) | 437 mF |
| (10) | 812 nF |
- 5) Second part to Problem 4: The dielectric is now removed. A charge per unit length of $+\lambda=1\text{C/m}$ is placed on the inner conductor and $-\lambda=-1\text{C/m}$ on the outer conductor. What is the energy density of the electric field at a point on the y axis a distance $r=1.5\text{mm}$ from the center. [5 points.]

- | | |
|------|-------------------------------|
| (1) | $6.4\text{E}16 \text{ J/m}^3$ |
| (2) | $6.4\text{E}15 \text{ J/m}^3$ |
| (3) | $1.6\text{E}14 \text{ J/m}^3$ |
| (4) | $4.0\text{E}13 \text{ J/m}^3$ |
| (5) | $9.4\text{E}15 \text{ J/m}^3$ |
| (6) | $1.6\text{E}16 \text{ J/m}^3$ |
| (7) | $7.7\text{E}15 \text{ J/m}^3$ |
| (8) | $6.4\text{E}14 \text{ J/m}^3$ |
| (9) | $4.0\text{E}14 \text{ J/m}^3$ |
| (10) | $3.8\text{E}15 \text{ J/m}^3$ |

- 6) An electric dipole pointing in the positive-z direction consisting of two equal and opposite point charges, $q=1\text{C}$ and $-q=-1\text{C}$, spaced 1mm apart sits centered at the point P: $(0,2.5\text{m},0)$ on the y-axis as shown. A uniform electric field of $\mathbf{E}=(5\mathbf{i} + 10\mathbf{j} + 20\mathbf{k}) \text{ N/C}$ is applied. Find the force on the dipole. [5 points.]

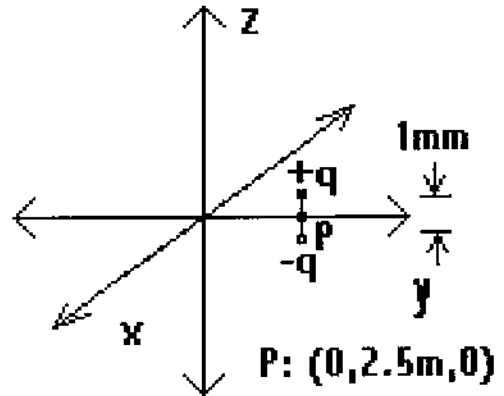

- (1) $(5\mathbf{i} + 10\mathbf{j} + 20\mathbf{k}) \text{ N}$
 - (2) $(-5\mathbf{i} - 10\mathbf{j} - 20\mathbf{k}) \text{ N}$
 - (3) $(10\mathbf{i} + 20\mathbf{j} + 40\mathbf{k}) \text{ N}$
 - (4) $(-10\mathbf{i} - 20\mathbf{j} - 40\mathbf{k}) \text{ N}$
 - (5) $5\mathbf{i} \text{ N}$
 - (6) $10\mathbf{i} \text{ N}$
 - (7) $10\mathbf{j} \text{ N}$
 - (8) $20\mathbf{j} \text{ N}$
 - (9) $-10\mathbf{i} \text{ N}$
 - (10) 0 N
- 7) Part II to Problem 6—What is the force on the dipole if the electric field is replaced by $\mathbf{E}=5(\text{V/m}^2) z \mathbf{k}$? [5 points.]

- (1) $5.0 \text{ mN } \mathbf{k}$
- (2) $-2.33 \text{ pN } \mathbf{i}$
- (3) $-10 \text{ mN } \mathbf{i}$
- (4) $3.99 \text{ } \mu\text{N } \mathbf{i}$
- (5) $10 \text{ mN } \mathbf{k}$
- (6) $4.35 \text{ mN } \mathbf{k}$
- (7) 0 N
- (8) $5.0 \text{ mN } \mathbf{j}$
- (9) $-1.39 \text{ pN } \mathbf{i}$
- (10) $-2.52 \text{ N } \mathbf{j} - 5.04 \text{ mN } \mathbf{k}$

8) A conductor is 10 meters long and has a uniform rectangular cross section of 3mm by 0.8mm. If the resistivity of the metal making up the conductor is $500\mu\Omega\text{-m}$ what is the resistance? [5 points.]

- (1) $1.2\text{E-}10 \Omega$
- (2) $1.2\text{E-}9 \Omega$
- (3) 2083Ω
- (4) $1.3\text{E-}5 \Omega$
- (5) 1757Ω
- (6) 176Ω
- (7) 208Ω
- (8) 537Ω
- (9) 53.7Ω
- (10) $37 \text{ m}\Omega$

9) Part II of 8. If a voltage of 1V is applied across the 10 meter conductor, what is the current density in the wire assuming it is uniform? [5 points.]

- (1) $100\text{A}/\text{m}^2$
- (2) $4.8\text{E-}4 \text{ A}/\text{m}^2$
- (3) $1.1\text{E-}9 \text{ A}/\text{m}^2$
- (4) $4.8\text{E-}3 \text{ A}/\text{m}^2$
- (5) $6.1\text{E-}2 \text{ A}/\text{m}^2$
- (6) $1.6\text{E-}2 \text{ A}/\text{m}^2$
- (7) $4.8\text{E-}6 \text{ A}/\text{m}^2$
- (8) $50 \text{ A}/\text{m}^2$
- (9) $133\text{A}/\text{m}^2$
- (10) $200\text{A}/\text{m}^2$

10) For the circuit in the diagram $C_1=5\text{nF}$, $C_3=10\text{nF}$, and the equivalent capacitance, $C_{eq}=10\text{nF}$ for the entire circuit. Find C_2 , for the circuit. [10 points.]

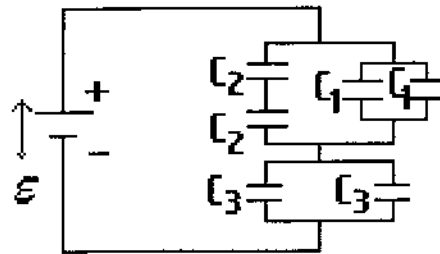

- (1) 5 nF
- (2) 20 nF
- (3) 8 nF
- (4) 15 nF
- (5) 35 nF
- (6) 33.5 nF
- (7) 10 nF
- (8) 430 nF
- (9) 2 nF
- (10) 1 nF

11) The following circuit has $E_1=100\text{V}$, $E_2=50\text{V}$, $R_1=100\Omega$, $R_2=150\Omega$. Find R_3 so that no current flows into or out of battery#2 (E_2). [10 points.]

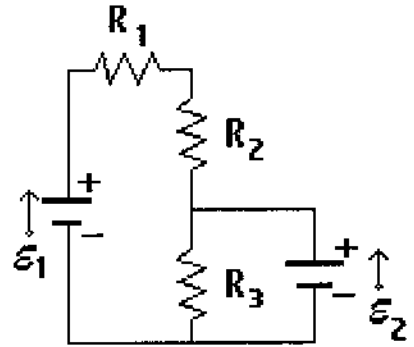

- (1) 100 Ω
- (2) 60 Ω
- (3) 190 Ω
- (4) 450 Ω
- (5) 150 Ω
- (6) 1000Ω
- (7) 250 Ω
- (8) 500 Ω
- (9) 50 Ω
- (10) 300 Ω

12) Find the voltage across the resistors, R_3 , for the circuit in the figure below. $R_1=100\Omega$, $R_2=200\Omega$, $R_3=50\Omega$, $R_4=180\Omega$, and $E=50\text{Volts}$. [10 points.]

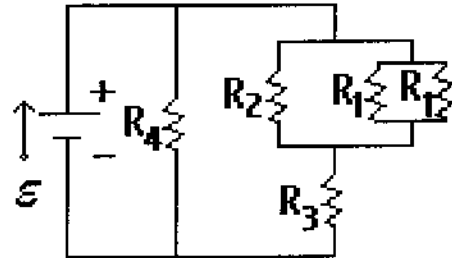

- (1) 24.7 V
- (2) 9.3 V
- (3) 40.7 V
- (4) 27.8 V
- (5) 8.8 V
- (6) 41.2 V
- (7) 22.2 V
- (8) 50 V
- (9) 26.3 V
- (10) 0 V

13) What is the time constant for charging capacitor C_2 in the circuit shown? [10 points.]

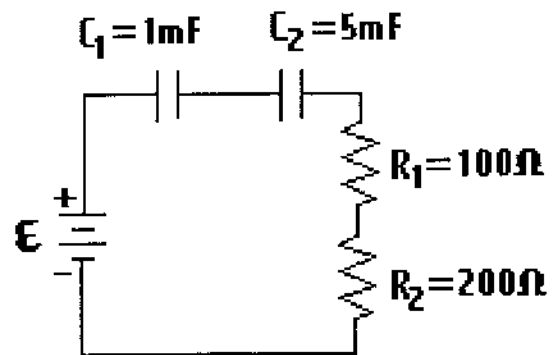

- (1) 1.8 s
- (2) 1.2 s
- (3) 1.5 s
- (4) 0.5 s
- (5) 0.25 s
- (6) 0.1 s
- (7) 1 s
- (8) 0.2 s
- (9) 0.17 s
- (10) 83 ms